

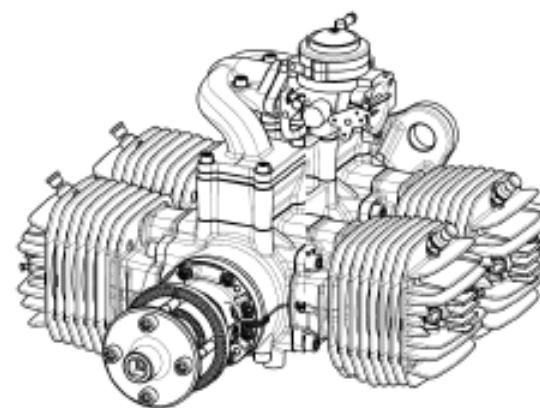

Anlage A

3W-684iB4 TS

1. Dreiseitenansicht

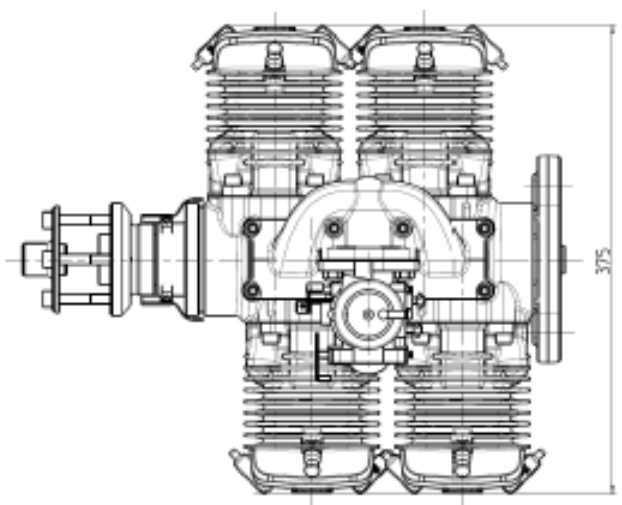
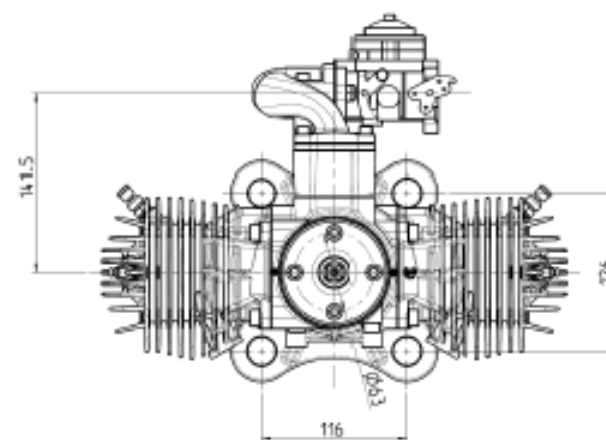
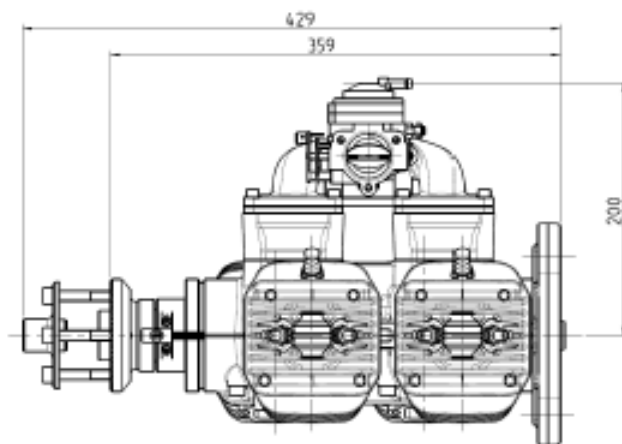

2. Bohrschablone

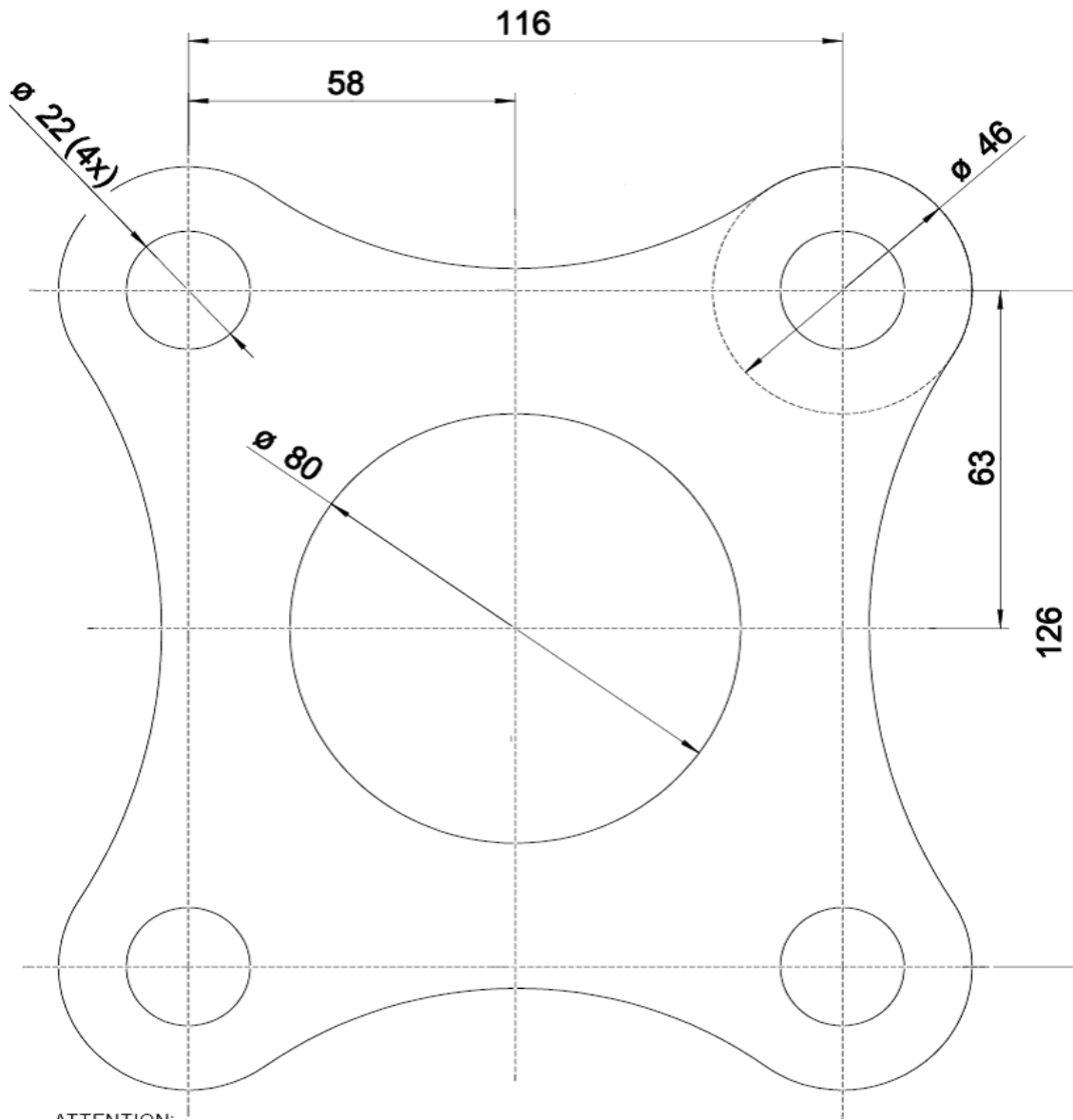

ATTENTION:



3. Technische Daten

	3W-684iB4 TS
Hubraum	684,0 ccm
Leistung	61,0 PS (44,8 KW)
Bohrung	66,00 mm
Hub	50,00 mm
Drehzahlbereich	1.200 – 6.500 U / min
Gewicht inkl. Zündung	16.350 g
Kurbelwelle	3 Kugellager
Pleuel	Nadellager an beiden Enden
Benzingemisch	1 : 50 – 1: 80 (min. 92 Oktan)
IIS – Zündung	6,0 – 8,4 V, 5 Zellen oder 2 Zellen LiPo
2-Blatt Propeller	40 x 18 CFK Bestellnummer 10.101.698 43 x 16 CFK Bestellnummer 10.101.699