

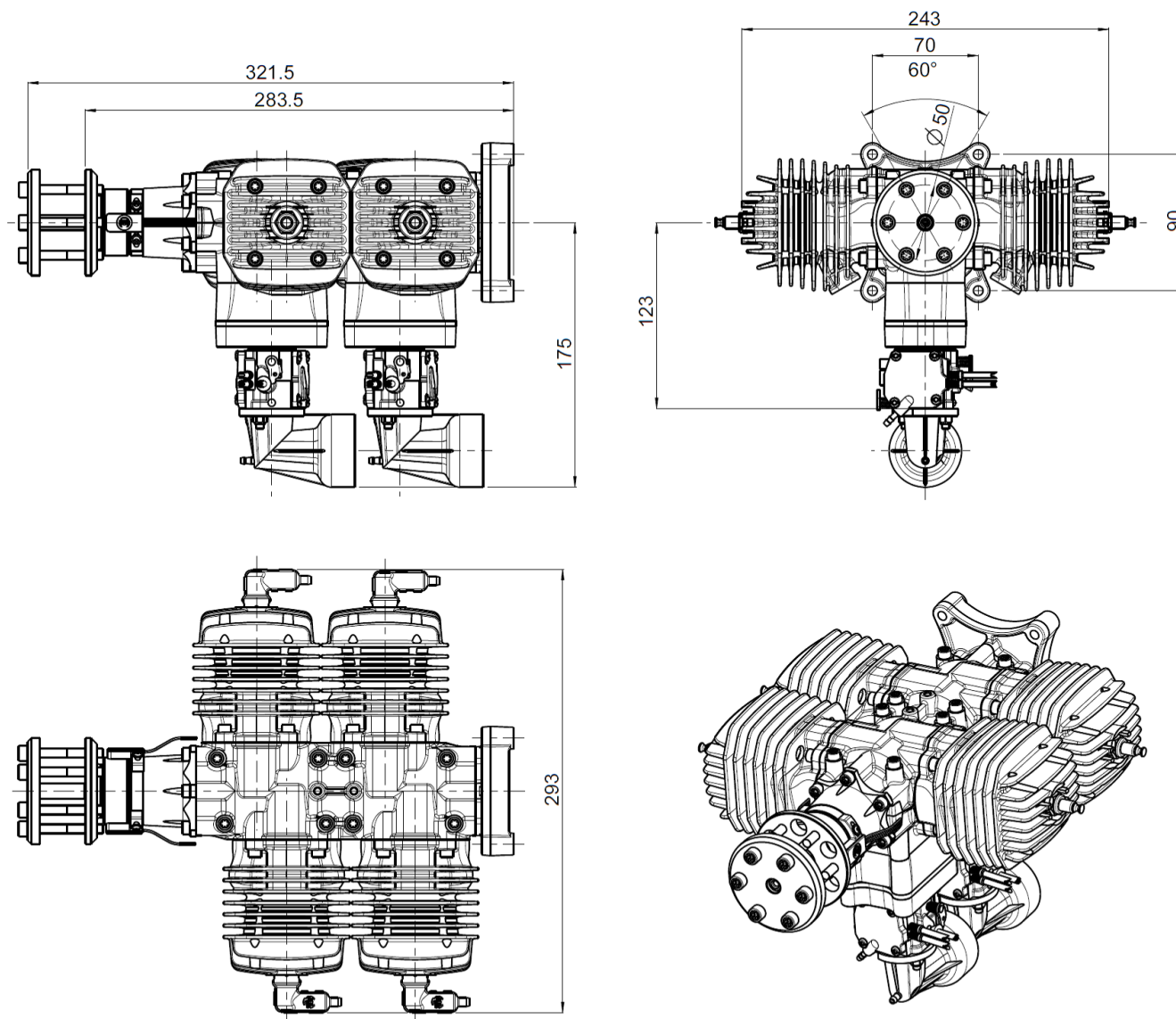

Annex A
3W-220iB4



1. 3-view drawing



2. Drilling template

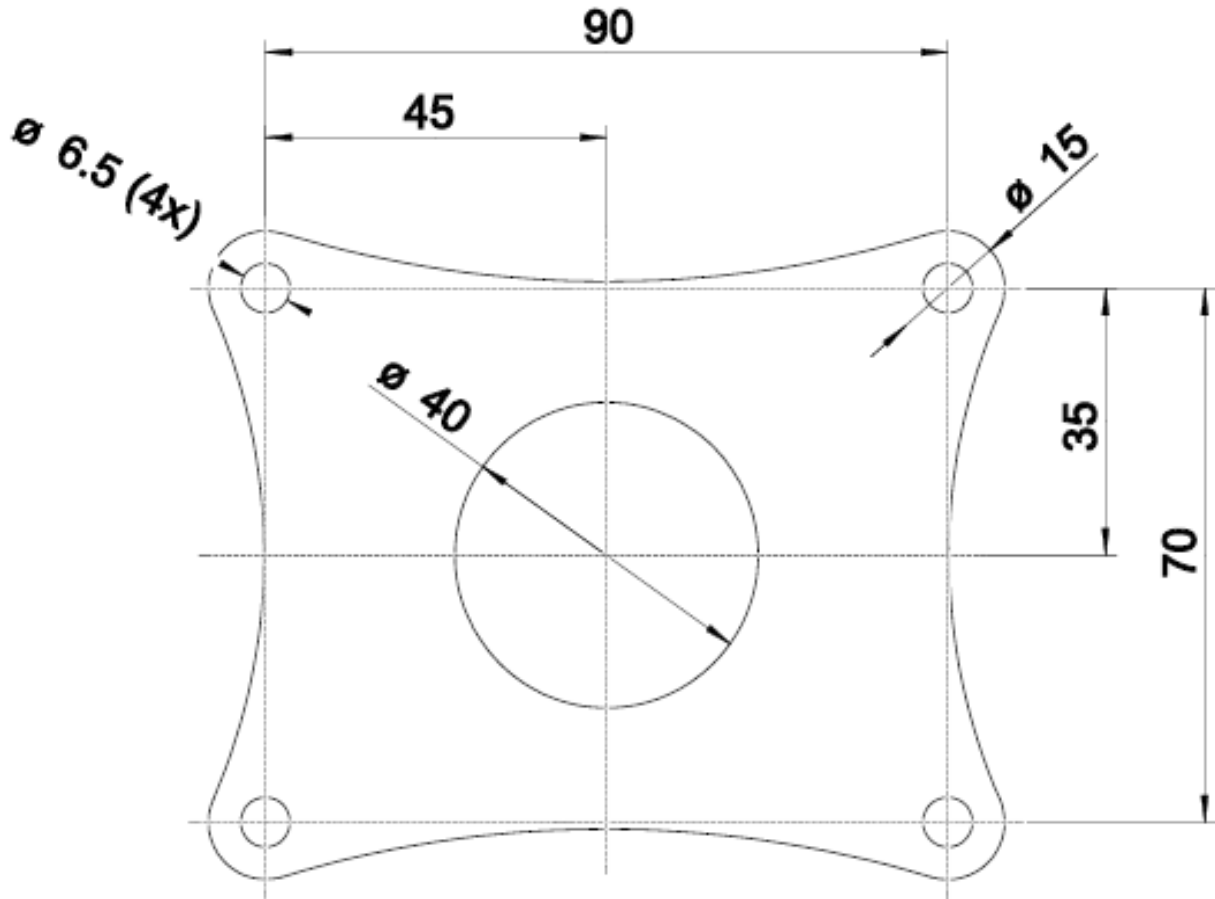



3. Specifications

	3W-220iB4
Cylinder capacity	220.0 ccm
Power	21.4 HP (16.0 KW)
Bore diameter	45.00 mm
Stroke	35.00 mm
Speed range	1,000 – 7,500 U / min
Weight, incl. ignition	6,200 g
Crankshaft	3 ball bearing
Rods	Needle bearings at both ends
Oil / gasoline ratio	1 : 50 – 1: 80 (min. 92 Octan)
IIS – ignition	6.0 – 8.4 V, 5 cells or 2 cells LiPo
2-blade propeller	34 x 10 wood part number 10.101.609 34 x 12 wood part number 10.101.613 32 x 14 CFK part number 10.101.690