

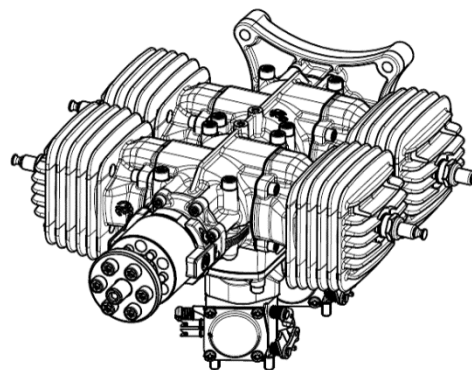

**Anlage A**

**3W-112iB4**

# 1. Dreiseitenansicht

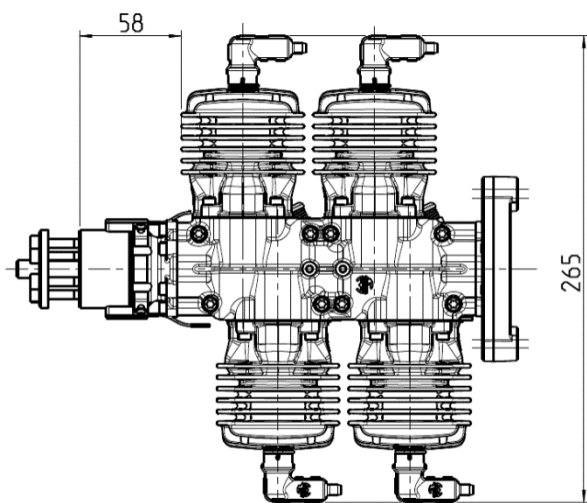
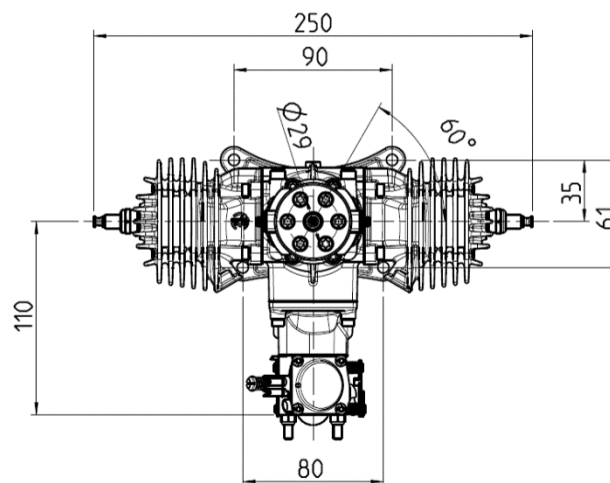
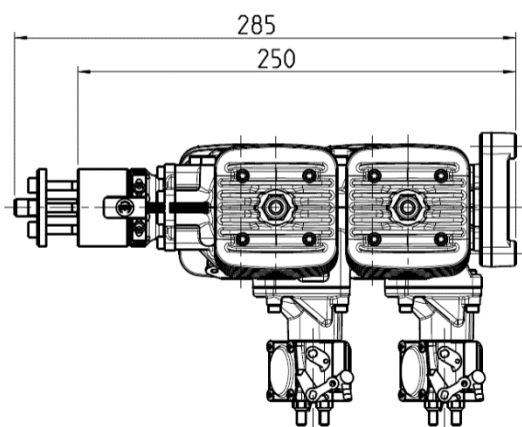

## 2. Bohrschablone

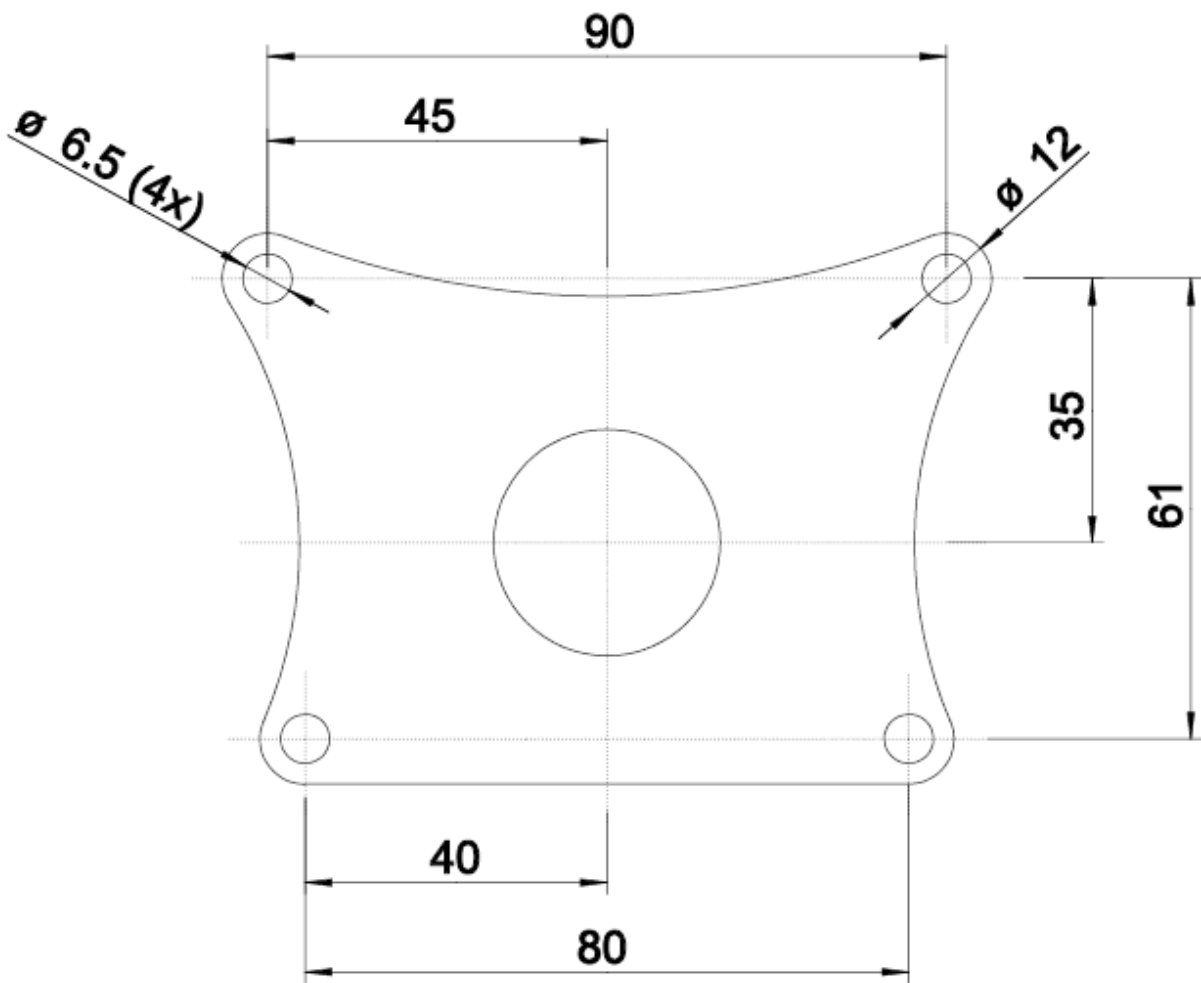



### 3. Technische Daten

	3W-112iB4
Hubraum	114,0ccm
Leistung	12,2 PS (9,0 KW)
Bohrung	36,00 mm
Hub	28,00 mm
Drehzahlbereich	1.100 – 7.000 U / min
Gewicht inkl. Zündung	3.870 g
Kurbelwelle	3 Kugellager
Pleuel	Nadellager an beiden Enden
Benzingemisch	1 : 50 – 1: 80 (min. 92 Oktan)
IIS – Zündung	6,0 – 84, V 5 Zellen oder 2 Zellen LiPo
2-Blatt Propeller	26 x 16 Holz Bestellnummer 10.101.569 27 x 10 Holz Bestellnummer 10.101.573 27 x 12 Holz Bestellnummer 10.101.577 28 x 10 Holz Bestellnummer 10.101.581 28 x 12 Holz Bestellnummer 10.101.585 30 x 10 Holz Bestellnummer 10.101.593
3-Blatt Propeller	26 x 10 CFK Bestellnummer 10.101.720 26 x 11 CFK Bestellnummer 10.101.730 27 x 14 CFK Bestellnummer 10.101.740